

# INSTALLTION INSTRUCTIONS

## LAMP READY STRIP FIXTURE



### IMPORTANT: READ ALL INSTRUCTIONS BEFORE THE INSTALLATION

**WARNING:** Risk of fire or electric shock. The installation should be performed only by a qualified electrician in accordance with the National Electrical Code and relevant local codes. This product must be installed in full accordance with applicable codes.

**TO PREVENT ELECTRICAL SHOCK, MAKE SURE TO TURN OFF MAIN POWER SWITCH PRIOR TO THE INSTALLATION.**

#### INSTALLATION INSTRUCTIONS

- Ensure that the ambient temperatures are within the luminaire's rated limits.
- Unpack the luminaire and the mounting hardware kit.

#### SURFACE MOUNT

1. Remove the cover (C) by unscrewing the twist latch (E).
  2. Rotate the end caps and snap sockets into place.
  3. Use the luminaire as a template by placing it on the junction box and marking in the four hole position. Put the luminaire aside and drill the four holes. Insert an anchoring bolt (not included) into each hole.
  4. Secure the luminaire into place with the help of mounting screws (not included) making sure to pass the junction box cables into the luminaire housing.
  5. Connect luminaire wires to junction box wires (wire connectors not included) as follows: ground wire to manufacturer's ground Wire, LIVE wire to manufacturer's power wire and neutral wire to manufacturer's neutral wire.
  6. Put the cover (C) on the installed luminaire and secure into place with the twist latch (E) and the screw (F) from either end.
- CAUTION! Carefully push the connecting wires into the luminaire.**
7. Install the lamps in the luminaire.
  8. Turn on the luminaire.

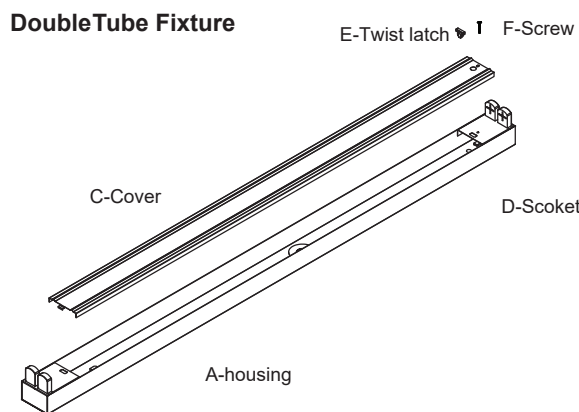

#### Method of Connecting Wire

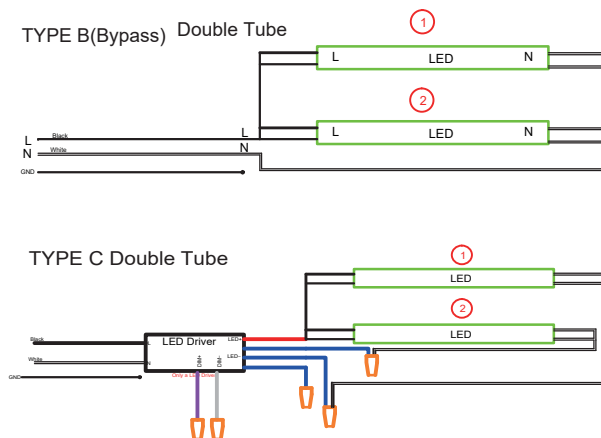

# INSTALLATION INSTRUCTIONS LAMP READY FIXTURE



## 1. Surface Mounting

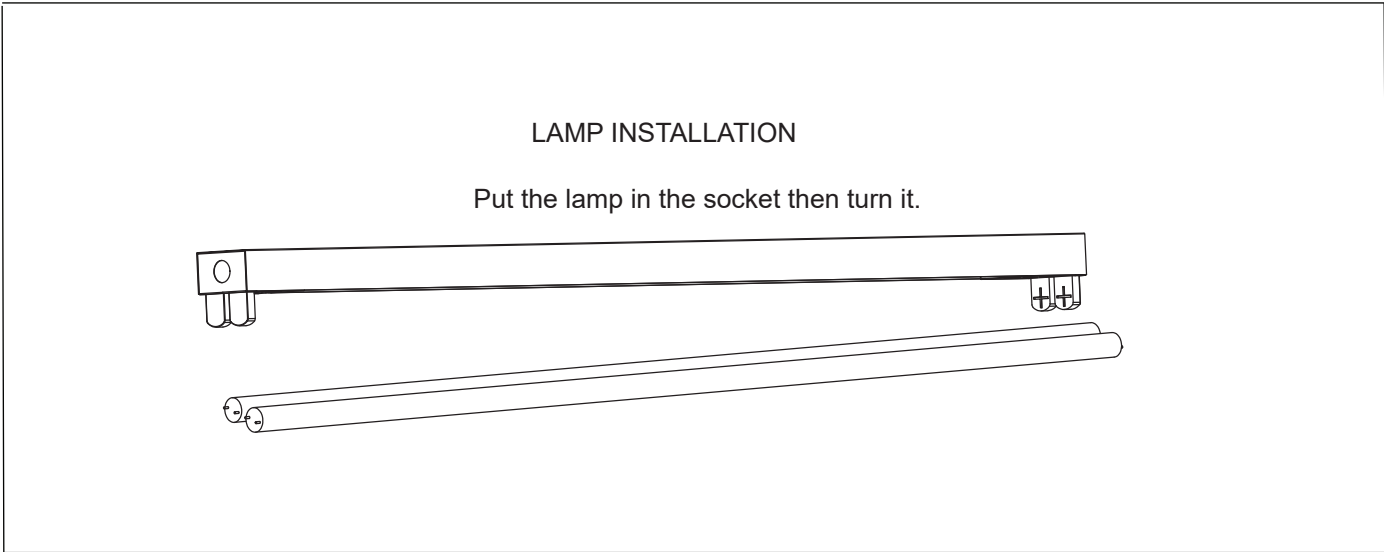
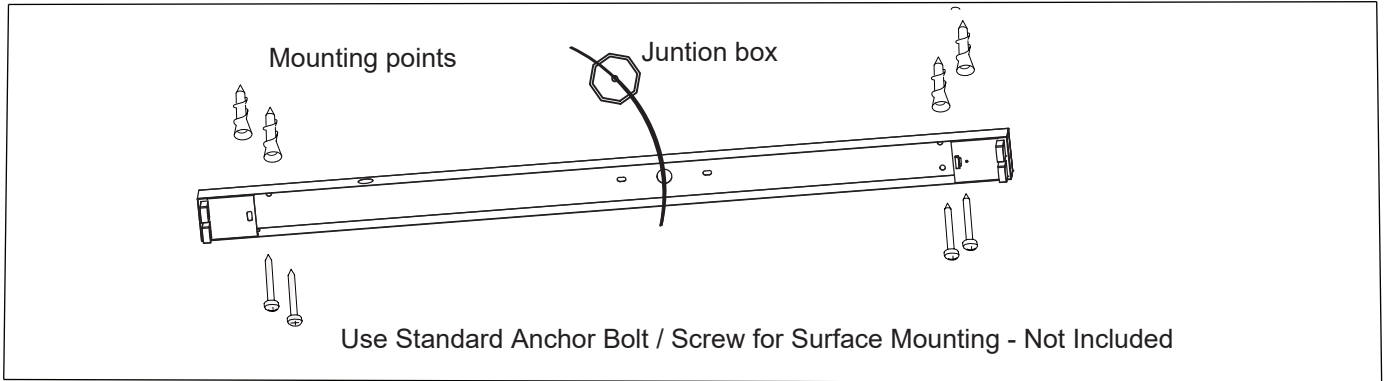

## 2. Suspending

### 1. V-hook and chain (not included)

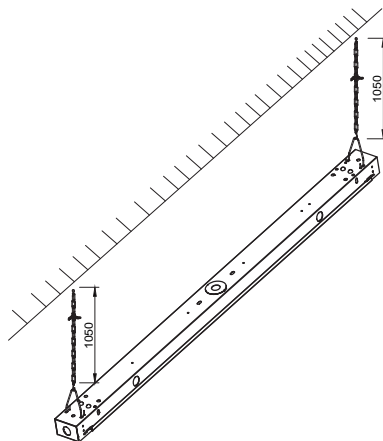

### 2. Aircraft cable (not included)

