

Emergency Wet Location Emergency Light Installation Instructions



When using electrical, basic safety precautions should always be followed including the following.

1. Disconnect power at fuse or circuit breaker before installing or servicing.
2. Suitable for wet location.
3. Do not mount in hazardous locations, or near gas or electric heaters.
4. Do not let power cords touch hot surface.
5. Equipment should be mounted in locations and at heights where it will not be subjected to tampering by unauthorized personnel.
6. The use of accessory equipment not recommended by the manufacturer may cause an unsafe condition.
7. Do not use this equipment for other than intended use.
8. All servicing should be performed by a qualified personnel only.
9. Allow battery to charge for 24 hours before first use.

SAVE THESE INSTRUCTIONS

MAINTENANCE

None required. Replace the batteries as needed according to ambient conditions. However, we recommend that the equipment be tested regularly in accordance with local codes.

OPERATION

Press the test button. The LED heads will turn on and the LED indicator will turn off. Release the test switch, LED indicator will turn on and the LED heads will turn off.

TROUBLE SHOOTING GUIDE

If LED heads or LED indicator does not illuminate, check the following:

1. Check AC supply - verify that unit has 24 hours AC supply.
2. Unit is shorted or battery is not connected.
3. Battery discharge. Permit unit to charge for 24 hours and then re-test.
4. Battery have to recharge if product keep in stock over 12 months, detail manual refer "BATTERY STOCK AND RECHARGE GUIDELINE".
5. If above trouble shooting hints do not solve you problem, contact factory for assistance.

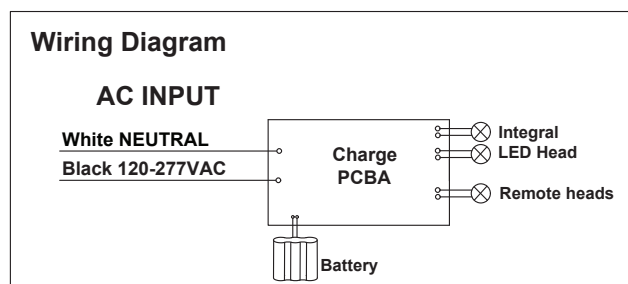
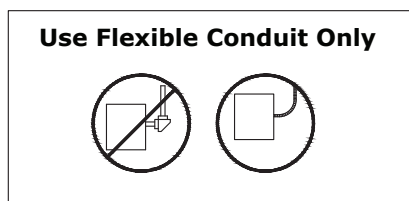

Emergency Wet Location Emergency Light Installation Instructions



Mounting Instructions

Maximum mounting height

Fixture should not be mounted exceed following height.

EMG-WLEM-WH

Wall Mount-Back Power Feed (see Fig 2)

1. Use Philip screwdriver loose 2 screws(see Fig 1).
2. Use flat blade screwdriver insert 2 middle slots and move clear cover from back plate.
3. Use flat blade screwdriver insert the two slots and pry off front cover from back plate.
4. Knockout cable hole and appropriate mounting hole in back plate.
5. Feed utility AC wires through the cable hole of back plate.
6. Secure back plate to J-box by screws.
7. Connect the fixture wires to the utility AC wires using the wire nuts provided. Connect the white wire to neutral, connect the black wire to the hot lead. Press back the wires into the J-box (Refer to Wiring diagram).
8. Connect remote heads. Refer to below instruction for remote heads.
9. Connect battery connector.
10. Snap the front cover onto the back plate.
11. Adjust the lamp head direction per needs.
12. Restore clear cover on the fixture.
13. Restore power and press test button. LED heads will turn on.

Ceiling Mount -Top Power Feed (see Fig 3)

Refer to above **Wall mount-Back Power Feed** instruction.
Just one difference:
Mount back plate on the ceiling surface instead of wall surface.

Connecting Remote heads (see Fig 2)

Optional function, only RC item with remote capability.
maximum remote capability 6V4.5W

Attach remote wire on remote connector on PCBA,
Connect remote heads extended wire to remote wire, yellow is positive(+), purple is negative(-). connect wires using wire nuts.

Open fixture

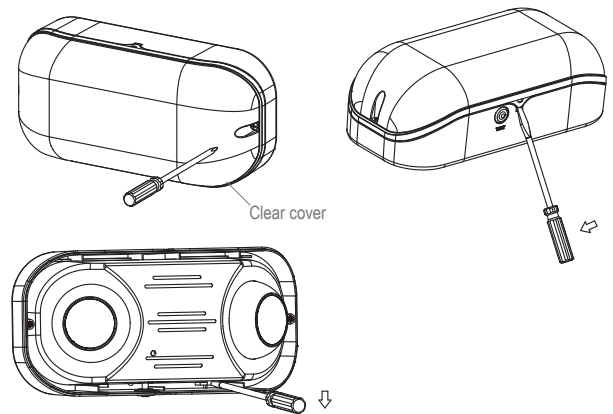

Fig 1

Wall mount-Back Power Feed

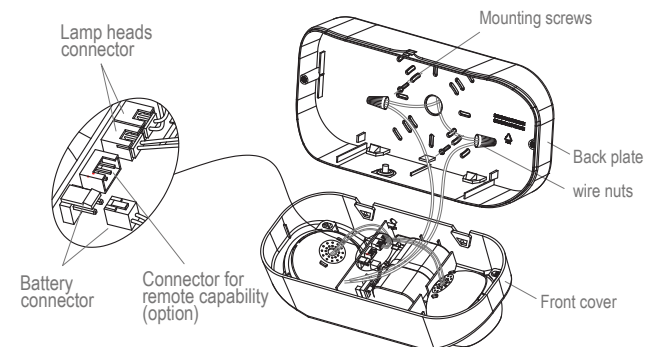

Fig 2

Ceiling mount-Top Power Feed

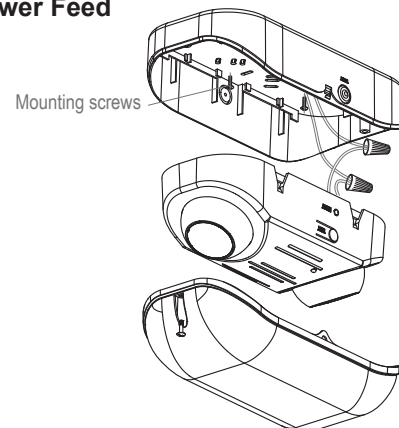

Fig 3

Emergency Wet Location Emergency Light Installation Instructions



4. Connect remote heads(Optional)

(1) Remove jump connector from the female connector on PCBA.

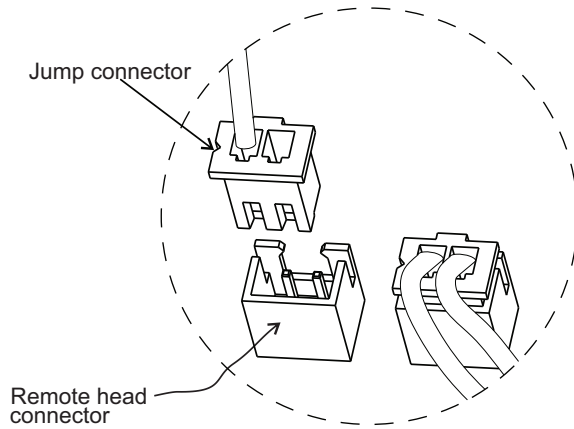

Figure 1

(2) Attach the remote male connector into the female connector on PC board.

(3) Connect extended remote head wires to the remote wires using wire nut. Yellow is positive(+) and the purple is negative(-).

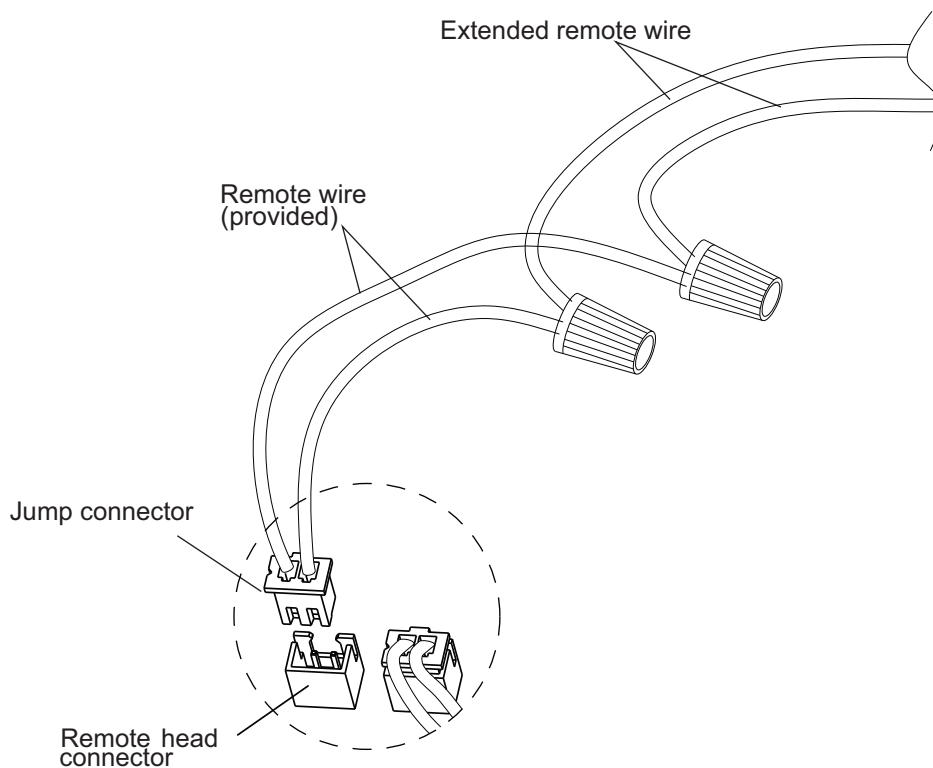

Figure 2